



BERETTA

serie 92 Stock
serie 92 Combat



Combat



Stock

Istruzioni per l'uso
Instructions for operation
Mode d'emploi

Allegato al libretto / enclosed to the booklet / annexe au livret
"Serie 92"

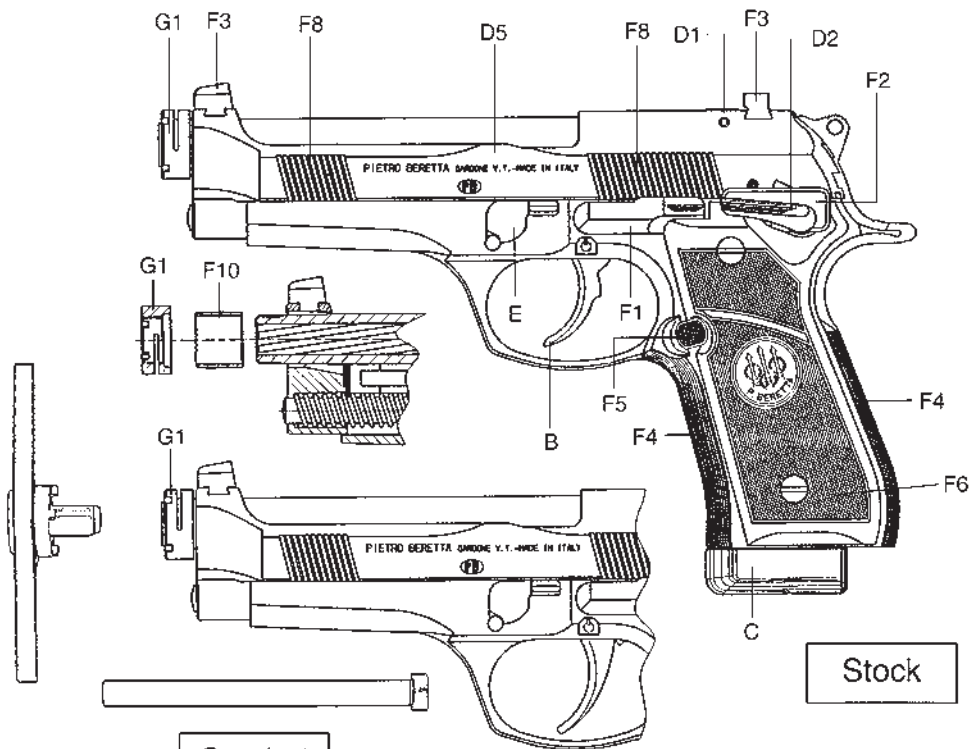

Combat

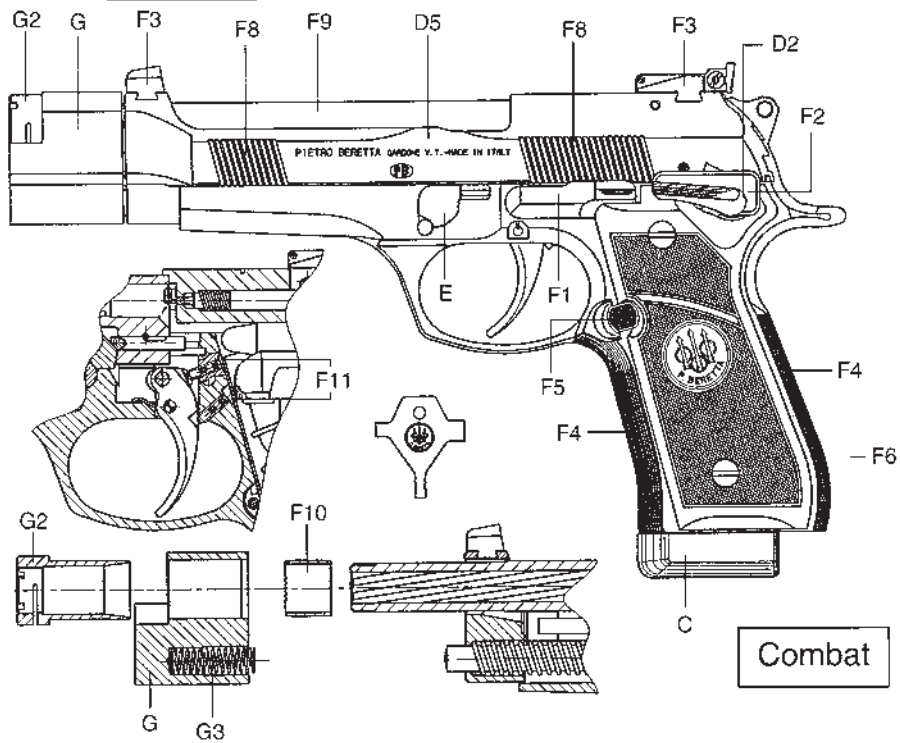

Combat

ENGLISH

Illustrations on page 2

DESCRIPTION

The new Beretta pistols series 92 Stock and series 92 Combat have been designed to assure the maximum results in the "Practical Shooting" competition in the Standard and Open categories. The characteristics of both series Stock and Combat meet all I.P.S.C. (International Practical Shooting Confederation) standards.

The new Combat models are available, according to specific countries, in the **short version** (125 mm barrel), in the **long version** (150 mm barrel) or in the **Combo version** (150 mm barrel and interchangeable 125 mm barrel).

Derived directly from the models 92FS, 98FS, 96, the Stock and Combat pistols differ from those models in the following aspects:

B. THE DOUBLE ACTION

Models Stock: double and single action.

Models Combat: single action only. The trigger pull in the Combat models with single action only has been softened to improve shooting precision.

C. THE GREAT FIRE CAPACITY

Models 92 and 98 (cal. 9 mm): 15-round staggered magazine.

Models 96 (cal. .40 S&W): 11-round staggered magazine.

All magazines feature a rubber magazine bumper.

D. THE COMPLETE SAFETY SYSTEM

D2. The manual safety on the frame locks the sear and the slide in the closed position. Both the Stock and Combat versions can be carried, during competition, in the cocked and locked position. The Stock models can also be carried locked with the hammer in the half-cocked position. On both models, the manual safety can be engaged when the hammer is decocked.

D5. New slide design: the slide is fortified in the side rail area and around the locking block lugs housing. The slight increase of the weight gives the gun better stability during firing.

F. THE FUNCTIONAL AND ANATOMICAL FEATURES

F2. Ambidextrous safety lever: the longer and wider levers make safety release easier and faster.

F3. Sights: front and rear sights are dovetailed into the slide for possible replacement. A 3-dot (white) system is used. The Combat models feature a fully adjustable rear sight (micrometric adjustment). The Stock models feature two interchangeable front sights which allow to modify the point of impact of ± 45 mm approximately at 25 meters.

F4. Checkered frame: the front and back straps of the grip are fully checkered to ensure a firm hold. The upper rear grip profile is undercut to better accommodate the web of the thumb.

- F 5. Oversized magazine release button:** the reversible magazine release button features exaggerated dimensions for competition use. The checkered surface secures elevated anti-slip properties.
- F 6. Black plastic grips:** the ultrathin black plastic grips feature a fine-line checkering to ensure a firm hold of the pistol under conditions of rapid, unaimed fire, even with wet hands. Aluminum alloy grips on request.
- F 8. Slide with double serrations:** the slide sides are notched front and back for easy push or pull manual operation.
- F 9. Long barrel with counterweight:** the long barrel Combat versions offer a 150 mm barrel with aluminum alloy counterweight sleeve.
- F10. Wear adjustable barrel-slide bushing:** replaceable after wear, the bushing mounted on the muzzle end of the barrel eliminates barrel-slide free play and improve the accuracy of the pistol.
- F11. Micrometric adjustment of the trigger:** the Combat versions feature a screw to adjust the trigger creep and a screw to adjust the trigger over-travel.

TECHNICAL FEATURES AND DATA

		92 Stock 98 Stock 96 Stock	92 Combat 98 Combat 96 Combat (Long barrel)	92 Combat 98 Combat 96 Combat (Short barrel)
Overall length	mm/"	217 / 8.5	242 / 9.5	217 / 8.5
Barrel length	mm/"	125 / 4.9	150 / 5.9	125 / 4.9
Overall width	mm/"	44,5 / 1.7	44,5 / 1.7	44,5 / 1.7
Overall height	mm/"	147 / 5.8	149 / 5.9	149 / 5.9
Weight unloaded (approx.)	gr./oz.	1035 / 36.5	1135 / 40	1035 / 36.5
Sight radius	mm/"	161 / 6.3	173 / 6.8	173 / 6.8
Magazine capacity	rounds	15-11 (96 Stock)	15-11 (96 Combat)	15-11 (96 Combat)

- Caliber **Models 92:** 9mmx19
 Models 98: 9mmx21 IMI
 Models 96: .40 S. & W.
- Action **Stock models:** double and single action. **Combat models:** single action only.
- Sights Dovetailed to slide. **Combat models:** fully adjustable rear sight (micrometric adjustment).
- Safeties **Automatic** firing pin safety. **Manual safety on the Frame:** it can be engaged with hammer cocked, lowered or in half-cock position if present.
- Grips Ultrathin black plastic, checkered. Aluminum alloy grips, on request.

LOADING AND FIRING

CAUTION: Always keep your finger away from the trigger whenever you do not intend to fire. Make sure the pistol is not already loaded by removing the magazine and retracting the slide in order to check that the chamber is empty.

CAUTION: Load the chamber only when ready to fire. In case of interruption of firing before the magazine is empty and the chambered round is fired, it is necessary to unload the pistol before lowering the hammer.

HOW TO LOWER THE COCKED HAMMER

- Strongly retaining the hammer with the thumb of the hand which holds the pistol, depress the trigger and allow the hammer to move slightly forward under thumb control. Simultaneously remove finger from trigger and cautiously let the hammer rotate until it stops on the half cocked position (if present) or in the fully lowered position.

CAUTION: Remember that the hammer cocked can be lowered only when the pistol is unloaded and the chamber is empty.

LOADING THE MAGAZINE

- Follow the instructions given in the "serie 92" manual, after you have checked that the pistol is unloaded.

LOADING THE PISTOL AND THE CARTRIDGE CHAMBER

CAUTION: Always keep your finger away from the trigger whenever you do not intend to fire.

- Push the loaded magazine into the pistol grip completely to ensure catch engagement.
- Grasping the slide serrations with thumb and index finger, fully retract and release the slide to load the chamber. The operation can be carried out either acting on the rear or on the front serrations taking care to keep the hand away from the muzzle. If using the front serrations, be careful not to pinch your hand in the chamber as it closes.

CAUTION: THE PISTOL IS NOW CHAMBER-LOADED WITH COCKED HAMMER, MANUAL SAFETY DISENGAGED AND READY TO FIRE by pulling the trigger. TO ENGAGE THE MANUAL SAFETY, push the safety lever up all the way so as to cover the red warning dot (the red dot is visible when the manual safety is disengaged).

NOTE: The Beretta pistols Stock and Combat, as well as the other 92 Beretta pistols, are equipped with an automatic safety which prevents firing pin inertia breech protrusion. This safety is overcome only by trigger pull.

To replace the round which has been chambered from the magazine, proceed as follows **remembering that you are handling a loaded weapon with a live round in the chamber:**

- Remove the magazine from the pistol by depressing the magazine release button.
- Insert one more cartridge into the magazine.
- Push the loaded magazine into the pistol grip completely to ensure catch engagement.

CAUTION: REMEMBER THAT YOU ARE HANDLING A LOADED GUN WITH A LIVE ROUND IN THE CHAMBER. Keep your finger away from the trigger whenever you do not intend to fire.

FIRING

WHEN READY TO FIRE:

- Aim the pistol and align front and rear sight on target.
- Release the manual safety by simply rotating the manual safety lever with a fully downward thumb pressure. The red warning dot can be seen when the manual safety is disengaged.
- Fire by squeezing the trigger.

NOTE: Since the hammer is cocked, the pull on the trigger simply releases the hammer letting it strike the firing pin. This firing mode is called **single action**.

The discharge will recoil the slide which, in turn, will eject the fired cartridge case, cock the hammer and activate the recoil spring. Then the slide will automatically close, feeding the next cartridge from the magazine into the chamber.

CAUTION: THE PISTOL IS STILL CHAMBER LOADED, COCKED AND READY TO FIRE AGAIN. Keep your finger away from the trigger whenever you do not intend to fire.

- When the last round has been fired the slide remains open.
- To fire again remove the empty magazine and insert a loaded one.
- Press the slide catch to close the slide and to load the chamber. **IMMEDIATELY ENGAGE THE MANUAL SAFETY.**

NOTE: The Stock models also feature **the double action** mode which allows the shooter, with the hammer fully lowered and the manual safety disengaged, to fire by squeezing the trigger. In this mode, the pull on the trigger will first cock the hammer and then release it to strike the firing pin.

UNLOADING THE PISTOL

It is a good practice to store the pistol unloaded, with empty magazine, with empty chamber and with decocked hammer.

- Engage the manual safety.
- Keep the pistol pointed in a safe direction and remove the loaded magazine.
- Grasping the slide serrations with thumb and index finger, fully retract the slide to remove the chambered cartridge.
- **WHEN SURE THAT THE CHAMBER IS EMPTY AND THE CARTRIDGE HAS BEEN EJECTED, QUICKLY RELEASE THE SLIDE.**
- Lower the cocked hammer.

UNLOADING THE MAGAZINE

- Follow the instructions given in the “Serie 92” manual.

MAINTENANCE

- Every time the pistol is fired, or at least once a month in case the pistol is not used for long time, cleaning and lubricating is recommended.

FIELD STRIPPING

Follow the instructions given in the “serie 92” manual.

- If separation of barrel from slide is required, disassemble in order the ring nut G2 and the bushing F10, the counterweight sleeve G and the spring G3 (Combat - long barrel models). It is recommended to carry out this operation when the gun is assembled. Proceed as follows:
- **Stock and Combat - short barrel models:** with the spanner supplied unscrew the front ring nut-bushing assembly and detach it from the barrel.
- **Combat - long barrel models:** with the spanner supplied unscrew the specific ring nut-bushing assembly. Detach it together with the counterweight sleeve from the barrel. Make sure not to loose the counterweight spring.

CLEANING AND LUBRICATING

- Follow the instructions given in the “serie 92” manual.
- If necessary clean and lightly oil the inside of the counterweight sleeve and the ring nut bushing assembly.

ASSEMBLING

- Follow the instructions given in the “serie 92” manual.

CAUTION: It is advisable to leave the conical bushing (F10) assembled with the front ring nut. Should the bushing be separated from the ring nut, it must be assembled with its smaller diameter end (marked with notches) towards the muzzle.

- **Stock and Combat - short barrel models:** assemble the conical bushing-front ring nut assembly on the barrel and screw on the ring nut using the supplied spanner.
- **Combat - long barrel models:** insert the bushing - specific ring nut assembly into the counterweight sleeve with spring and assemble them on the barrel. Make sure the recoil spring guide enter the counterweight sleeve hole compressing the spring. Screw on the ring nut with the supplied spanner.
- Open and close the slide two or three times. Tighten the ring nut making sure that the slide goes completely into the locking position.

ADJUSTING THE REAR SIGHT

Combat models: Adjusting the rear sight is done by aligning front and rear sight on the mark. To modify rear sight adjustment proceed as follows:

- **ELEVATION: to raise the point of impact on target,** turn the upper screw counter-clockwise using the sight spanner supplied. Proceed one sector (click of the screw) at a time so that the finest adjustment is obtained. **To lower the point of impact,** proceed in reverse.
- **WINDAGE: to move the point of impact to the right** turn the side screw clockwise proceeding one sector at a time so that the finest adjustment is obtained. **To move the point of impact to the left** proceed in reverse.

HOW TO ADJUST THE TRIGGER OVERTRAVEL

Combat models only: with the 1,5 mm hexagonal key supplied unscrew (counter-clockwise) the lower hexagonal dowel on the frame to increase the trigger overtravel and viceversa.

HOW TO ADJUST THE TRIGGER CREEP

Combat models only: with the 1,5 mm hexagonal key supplied unscrew (counter-clockwise) the upper hexagonal dowel on the frame to increase the trigger creep and viceversa.

THESE OPERATIONS SHOULD BE CARRIED OUT WHEN THE PISTOL IS DISASSEMBLED.

HOW TO REVERSE THE MAGAZINE RELEASE BUTTON

Follow the instructions given in the "serie 92" manual.

MALFUNCTIONS, CAUSES AND REMEDIES

Follow the instructions given in the “serie 92” manual.

Le illustrazioni e descrizioni di questo opuscolo si intendono fornite a titolo indicativo. La Casa si riserva pertanto il diritto di apportare ai suoi modelli, in qualsiasi momento e senza preavviso, quelle modifiche che ritenesse utili per migliorarli o per qualsiasi esigenza di carattere costruttivo e commerciale.

The illustrations and descriptions given in this brochure are intended as a general guide only, and must not be taken as binding. The Company, therefore, reserves the right to make, at any moment and without notice, any changes it thinks necessary to improve its models or to meet any requirements of manufacturing or commercial nature.

Les illustrations et les descriptions contenues dans ce prospectus ne sont données qu'à titre indicatif. La Maison se réserve le droit de modifier, à tout moment et sans préavis, ses modèles pour les améliorer ou pour n'importe quelle exigence de caractère constructif et commercial.

Beretta - cod. 61095.000
4/97 (3)

Printed in Italy
batan - Gardone V.T.



Fabbrica d'Armi Pietro Beretta S.p.A.
Via Pietro Beretta, 18
25063 GARDONE VAL TROMPIA (Brescia) Italia
Tel. (030) 8341.1 - info@beretta.com
www.beretta.com

