

# DISTINGUISHED .357 COMBAT MAGNUM® REVOLVER MODEL No. 686

PARTS LIST

INSTRUCTIONS FOR USE

MAINTENANCE

## SPECIFICATIONS



## SPECIFICATIONS

**Frame Designation** . . . . . "L"  
**Caliber** . . . . . .357 Magnum / .38 S&W Special  
**Capacity** . . . . . .6 Shots  
**Barrel** . . . . . Heavy straight barrel with full-length extractor shroud  
 4" — actual length 4 1/8"; 6" — actual length 5 7/8"  
**Hammer** . . . . . .375" width semi-target hammer  
**Trigger** . . . . . .312" width smooth combat trigger  
 All four-inch revolvers furnished with target accessories (hammer and trigger) will be equipped with a trigger stop. All six-inch revolvers will be equipped with a trigger stop. Standard four-inch models will not have a trigger stop.  
**Overall Length** . . . . . 4" barrel — 9 3/4 inches; 6" barrel — 11 1/2 inches

**Weight** . . . . . 4" barrel, empty, 42 oz. (1191g)  
 6" barrel, empty, 46 oz. (1,304g)  
**Front Sight** . . . . . 4" — 1/8 Baughman with S&W Red Ramp  
 6" — Plain Patridge or Baughman with S&W Red Ramp  
**Rear Sight** . . . . . S&W micrometer click sight, adjustable windage and elevation. Plain blade or white outline notch in conjunction with red ramp, plain blade with Patridge front sight.  
**Sight Radius** . . . . . 4" barrel — 6 inches; 6" barrel — 8 inches  
**Stocks** . . . . . Checkered Goncalo Alves Target with speed loader cutaway (same size as "K" frame).  
**Finish** . . . . . S&W satin stainless  
**Material** . . . . . M686 — Stainless steel

NOTE: When your Model 586 or 686 is equipped with a high Patridge front sight and a .146 rear sight slide to achieve the neck hold position, for Practical Police Pistol Combat Shooting, utilizing 158 grain round nose lead .38 Special caliber factory ammunition, the following approximate sight setting is applicable:

- 7 yards — point of aim — 22 clicks from bottom position
- 15 yards — point of aim — 26 clicks from bottom position
- 25 yards — neck hold — 3 clicks up from the bottom
- 50 yards — neck hold — 22 clicks up from the bottom

These adjustments are approximate and will vary with the shooter's eye and slight variation in the mechanics of the sight. If you find with the .146 rear sight slide that the desired impact height cannot be achieved, it will be necessary to purchase a .160" rear sight slide with windage screw and nut for installation in your sight assembly.



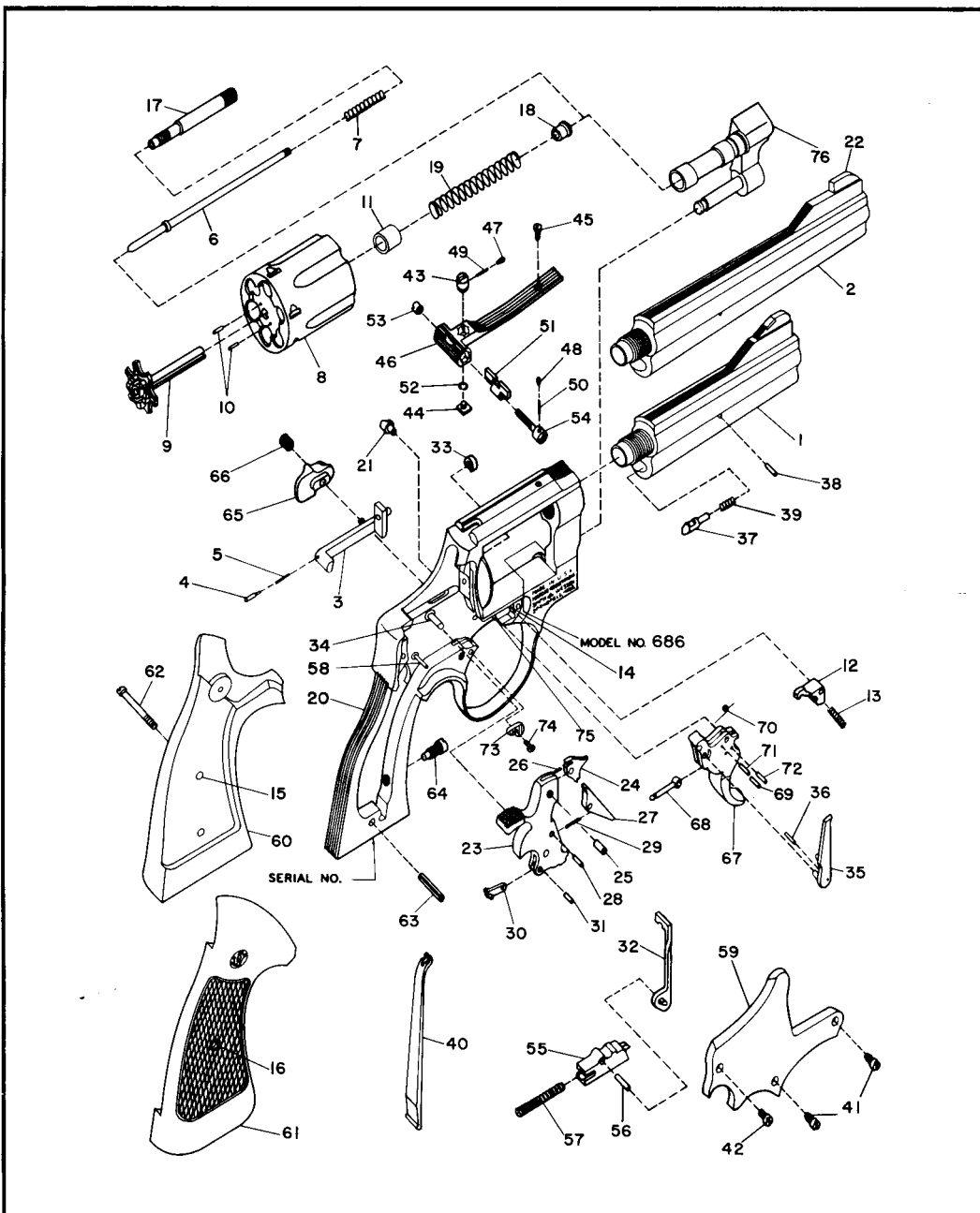

This isometric drawing and parts list conform to the current specifications provided by our Engineering Department. From time to time improvements are made in all our models. For this reason, the gun which you own may not correspond exactly with the information provided on this sheet. When requesting information or ordering parts for your gun, please provide the serial number and approximate date of purchase.

The Smith & Wesson .357 Distinguished Combat Magnum® target revolver is a 6-shot breech-loading hand weapon. It is produced with a solid frame and a swing-out type of cylinder, having 6 chambers around a central axis so that 6 shots may be fired before reloading is necessary. The weapon may be fired either single action or double action, and cocking the hammer by either method causes the cylinder to rotate and align the next chamber with the barrel. The rate of fire is limited only by the dexterity of the operator in reloading the cylinder and his ability to aim the weapon and pull the trigger.

Loading and firing this revolver is a comparatively simple operation, as follows:

Push the thumbpiece forward. This will release the cylinder so that it may be swung out to the left side for loading. Holding the gun so that the cylinder is in its outermost position, and with the muzzle pointing downward, insert cartridges in the charge holes making certain that they are firmly seated. Return the cylinder to its original position in the frame, pressing it firmly into place to make sure that it locks in alignment. The gun is now ready to fire.

In single action shooting the hammer is pulled or cocked to its extreme rearward position. The gun may then be fired by merely pressing the trigger. This type of shooting is used for deliberate fire where there is time to sight the gun carefully and squeeze the trigger in an unhurried fashion. It is also used in competitive shooting for not only slow fire but also for timed fire, whereby 20 seconds are allowed for the firing of each 5 shots, and rapid fire where 10 seconds are allowed for the firing of each 5 shots.

There is time even in rapid fire shooting for the deliberate handling of the gun in single action fashion just so long as the function is performed without loss of time and in a definite cadence whereby the cycle will be completed within the allocated time.

Where time or other circumstances do not allow for single action fire the revolver is used double action. To fire double action all that is necessary is to align the weapon with the object which you wish to hit and pull the trigger firmly all of the way to the rear. This will cause the hammer to rise to its full cocked position and then fall to explode the cartridge, and as previously stated the only limit to the speed with which a weapon can be manipulated in this fashion will be determined by the dexterity of the shooter. This type of shooting is required in combat work or under emergency conditions where the gun must be used with great speed.

To extract the fire cases press the thumbpiece forward and swing the cylinder out to the left side. Turn the gun muzzle upward and holding the cylinder in its extreme outward position press down sharply on the extractor rod. This will eject the fired cases down and out of the gun, which is now ready to reload.

# MODEL No. 686

## PARTS LIST

Item No.	Part No.	Description	Item No.	Part No.	Description
1	075390000	*Barrel, 4 1/8", Red Ramp, Forged	38	075430000	Locking Bolt Pin
1	071990000	*Barrel, 6", Red Ramp, Forged	39	070140000	Locking Bolt Spring
2	075710000	*Barrel, 6", Patridge, Forged	40	070160000	Mainspring
2	075880000	*Barrel, 6", Patridge, Pinned	41	070170000	Plate Screw, Crowned Hd.
		.908 Hgt.	42	070370000	Plate Screw, Flat Hd.
3	075230000	Bolt	43-54	075550000	Rear Sight Assy.
4	070980000	Bolt Plunger			Includes:
5	070200000	Bolt Plunger Spring	43	071790000	R.S. Elevation Nut
6	074720000	Center Pin	44	071800000	R.S. Elevation Stud
7	074640000	Center Pin Spring	45	071820000	R.S. Leaf Screw
8-11	075210000	*Cylinder Assy.	46	071810000	R.S. Leaf
		Includes:	47	071580000	R.S. Plunger
8	075210000	Cylinder (1)	48	071580000	R.S. Plunger
9	075190000	*Extractor	49	071590000	R.S. Plunger Spring
10	072620000	Extractor Pin	50	071590000	R.S. Plunger Spring
11	074270000	Gas Ring	51	071850000	R.S. Slide
12	070460000	Cylinder Stop	52	071860000	R.S. Spring Clip
13	070550000	Cylinder Stop Spring	53	071870000	R.S. Windage Nut
14	070310100	Cylinder Stop Stud	54	071880000	R.S. Windage Screw
15	040670000	Escutcheon	55-56	072930000	Rebound Slide Assy.
16	040680000	Escutcheon Nut			Includes:
17	070050000	Extractor Rod	55	070340000	Rebound Slide (1)
18	070530000	Extractor Rod Collar	56	070320000	Rebound Slide Pin
19	075460000	Extractor Spring	57	070280000	Rebound Slide Spring
20	075300000	*Frame	58	070310100	Rebound Slide Stud
21	070150000	Frame Lug	59	070410000	*Side Plate
22	075890000	Front Sight Blade, Patridge,	60-62	164000000	Stock Assy., Sq. Butt, Chkrd
		.823 Hgt.			Goncalo Alves
22	075900000	Front Sight Blade, Patridge,			Includes:
		.908 Hgt.	60	045640000	Stock, Left
—	070130000	Front Sight Pin, N.I.	61	072260000	Stock, Right
23-31	047280000	Hammer Assy.	62	071290000	Stock Screw
		Includes:	63	070220000	Stock Pin
23	047010000	Hammer (1)	64	071290000	Strain Screw
24	075130000	Hammer Nose	65	070240100	Thumbpiece
25	057700000	Hammer Nose Rivet	66	070250000	Thumbpiece Nut
26	072960000	Hammer Nose Spring	67-72	047290000	Trigger Assy.
27	070390000	Sear			Includes:
28	070190000	Sear Pin	67	050000000	Trigger (1)
29	070200000	Sear Spring	68	070270000	Trigger Lever
30	070210000	Stirrup	69	070190000	Trigger Lever Pin
31	070190000	Stirrup Pin	70	070400000	Hand Torsion Spring
32	071150000	Hammer Block	71	070190000	Hand Spring Pin
33	071240000	Hammer Nose Bushing	72	070190000	Hand Spring Torsion Pin
34	070380100	Hammer Stud	73	074430000	Trigger Stop
35	075220000	Hand	74	071820000	Trigger Stop Screw
36	070110000	Hand Pin	75	070300100	Trigger Stud
37	070590000	Locking Bolt	76	075170000	*Yoke

\*Requires Factory Installation

Smith & Wesson will refinish handguns of its own manufacture. No change of finish is offered on the Victory or Airweight® model or on Models 28, 39, 59, 60, 63, 64, 65, 66, 67, 439, 459, 629, 681, or 686. Repair or replacement of parts are in addition to refinishing price.

### SERVICE

Should your Smith & Wesson revolver require adjustment, repair, or refinishing, we recommend most sincerely that the weapon be returned to the factory or authorized service center. There is no other way to insure that the work will be done in a properly equipped and staffed shop.

Charges are very reasonable, being based on the cost of parts replaced plus a labor charge for the time expended on the job. A labor charge for one hour is usually sufficient to cover all but very extensive overhaul jobs.

Revolvers returned to the factory or authorized service center should be MARKED FOR THE ATTENTION OF THE SERVICE DEPARTMENT. A letter of instructions

should be enclosed with the gun, and shipment must be made Prepaid. Adherence to these suggestions will prevent loss of time in handling at the factory.

When returning guns for service, please remove custom stocks and holsters. We cannot assume responsibility for these items.

When your revolver arrives for service, it will be very carefully inspected, together with your letter of instructions. Next, a quotation covering total cost of work to be performed will be sent to you. No actual work will be commenced before receiving your approval of our quotation.

**SEE YOUR AUTHORIZED SMITH & WESSON  
SERVICE CENTERS LIST FOR YOUR LOCAL SERVICE CENTER**

## HELPFUL HINTS

1. Push thumb piece forward, swing out cylinder and load.
2. Close cylinder and take position on firing line.
3. **STAND** in a relaxed and comfortable position, feet well apart. The arm when raised should line naturally with the target. If it does not, shift the feet a bit.
4. **HOED** the gun firmly but do not seize it with a "death grip." If the knuckles are white, the grip is too tight.

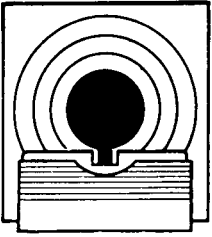

5. **LINE** the sights carefully, top of front sight even with top of rear notch, and light equal on both sides of front sight (see illustration).

6. **SQUEEZE** the trigger with trigger finger only, carefully keeping the sights aligned on the target. **SQUEEZE** is the most important function of shooting. A pull or yank on the trigger will surely disturb alignment and result in a poorly placed shot or a

complete miss. **DO NOT** apply the **SQUEEZE** with the whole hand. The squeeze should be applied between the tip and first joint of the trigger finger. Slowly at first — speed will develop with practice.

7. Watch the sights. Learn to "call your shots" before looking for them on the target. Practice "dry shooting" with empty gun. Watch sights when hammer falls. If sights jump or duck you are not squeezing the trigger. Don't hold the shot too long. If the sights don't line up on the target in 15 seconds, take the arm down and rest for a moment. Remember, good revolver shots are not born; they are made by careful and consistent practice.

## SIGHT ADJUSTMENT

1. Front sight is fixed. All adjustments must be made at the rear sight.
2. Move the rear sight in the direction in which you wish the group on the target to move. (If group must be higher, elevate the rear sight. If group must go to the right, move the rear sight to the right, etc.)
3. To elevate rear sight turn top (elevating) screw to the left, or counter-clockwise. To depress rear sight turn top (elevating) screw to the right, or clockwise.
4. To move rear sight to right, turn side (windage) screw to the right, or clockwise. To move rear sight to left, turn side (windage) screw to the left, or counter-clockwise.
5. Each click of the rear sight moves the point of impact on the target approximately  $\frac{3}{8}$ " elevation and  $\frac{1}{4}$ " windage at 50 yards and half of that amount at 25 yards.

## INSTRUCTIONS FOR USE

### Care and Cleaning

Many weapons require stripping or at least partial disassembly in order to clean and oil them properly. This does not apply to the revolver, which may be cleaned and lubricated under all normal circumstances without removing a single pin or screw.

If at any time disassembly of the weapon is indicated for repairs, etc. it is recommended that the gun be returned to the factory, or you should at least employ the services of a qualified gunsmith.

To keep revolvers in proper condition, and to insure perfect functioning in time of need, it is essential that they be kept clean and coated with a rust inhibiting oil. Care is required to prevent rust, especially in damp, humid climates, or when sweaty hands come in contact with the guns.

To clean the revolver as required when the weapon is not fired, or when kept in storage, rub it externally with a lightly oiled cloth, and then swab out the bore and cylinder chambers with an oily flannel patch. Remove excess oil but leave a light film to protect the arm against rusting. Clean out all crevices with a small clean brush.

For cleaning after firing, scrub out the bore and chambers with an approved nitro solvent, and then use a brush dipped in solvent to remove all deposits from around the breech of the barrel, extractor head, and other adjacent areas which have been subjected

to the action of powder or primer residue. If there is any evidence of lead particles, or other foreign matter left in bore or chambers, it is well to scrub these parts further with a bronze or brass brush dipped in powder solvent. The area under the extractor should be cleaned frequently and kept dry, as an accumulation of powder residue can cause the cylinder to bind.

After cleaning off the entire gun with nitro or powder solvent, remove all traces of the solvent, both on the exterior of the gun and in the bore and chambers, following immediately thereafter with the application of a light film of oil. Note that there is usually some residue in the steel of both barrel and cylinder that works out and becomes apparent within from 24 hours to 48 hours after the initial cleaning. This can be removed with a bristle brush with perhaps a light re-application of powder solvent, after which the oil film should be re-established on all surfaces.

The above applies if ammunition used is of American manufacture, incorporating smokeless powders and non-corrosive primers. If other than smokeless powders and non-corrosive primers are used in these revolvers then cleaning methods should be adjusted accordingly.

Do not store revolvers with a plug in the barrel, since this is a contributing factor to sweating. By the same token, maintenance or storage rooms should be kept at a constant temperature with the least possible humidity, and the guns should *not* be stored encased in anything which will attract or hold moisture, such as leather.

If revolvers are to be stored for a long period of time, the internal mechanism of the lockwork should be heavily oiled with an acid free lubricating oil, and the exterior of the guns, as well as the bore of the barrel and the charge holes of the cylinder, should be heavily coated with an anti-rust oil. It is an established fact that moisture is the greatest enemy of metallic objects, particularly in climates where temperature and humidity are high, and salt air is present. Extreme care should be exercised that all metallic surfaces be kept clean and oiled, and the wood stocks on the revolvers should be inspected for cracks caused by moisture. A periodical coat of raw linseed oil, well rubbed in with the hand, will help to prevent the splitting of stocks, but care must be exercised that the linseed oil does not get into the mechanism or on moving parts, as it has a tendency to gum when dry.

### Safety Precautions

Before proceeding to use this weapon, a word of caution is in order. This gun is as safe to handle and use as we can make it, but there is no foolproof firearms. Used correctly by a competent person the revolver is one of the safest handguns. There are many safety rules but those found below are basic, and should be observed rigidly until they become second nature.

1. The gun must always be checked for live ammunition when picked up, drawn from the holster, or handed to or accepted from another individual.
2. The gun should always be holstered except when drawn for a definite purpose.
3. Never point the revolver at anything that you do not intend to shoot.
4. Do not cock the gun unless you intend to shoot it. Do not even insert the finger in the trigger guard until you are ready to fire.
5. Dry-snapping, even with dummy cartridges, should be discouraged unless same is performed on a regular target range or at a known inanimate target object.
6. When the handgun is out of the holster and held in a ready position, be absolutely certain that it is not pointing an any part of yourself or the persons of others who are in your immediate vicinity.
7. Beware of obstructions in the barrel. If, when firing, a weak or peculiar report is heard, cease firing at once and inspect the barrel for an obstruction. A stuck bullet, or any other object in the barrel, should be removed immediately, since even a plug of mud, snow, twigs, or an abnormal quantity of heavy grease in the bore, may result in a bulged or burst barrel.
8. At all times treat the revolver as the precision instrument that it actually is.

**MAKE SAFE GUN HANDLING A HABIT.**